

# USER'S INFORMATION MANUAL

## PUREFIRE® GAS BOILERS

**TO THE INSTALLER:** *This manual is the property of the owner and must be affixed near the boiler for future reference.*

**TO THE OWNER:** *This boiler should be inspected annually by a Qualified Service Agency.*

### **WARNING**

If the information in this manual is not followed exactly, a fire or explosion may result causing property damage, personal injury or loss of life.

– Do not store or use gasoline or other flammable vapors and liquids in the vicinity of this or any other appliance.

#### – **WHAT TO DO IF YOU SMELL GAS**

- Do not try to light any appliance.
- Do not touch any electrical switch; do not use any phone in your building.
- Immediately call your gas supplier from a neighbor's phone. Follow the gas supplier's instructions.
- If you cannot reach your gas supplier, call the fire department.

– Installation and service must be performed by a qualified installer, service agency or the gas supplier.

### **MISE EN GARDE**

Négliger de suivre ces instructions à la lettre pourrait provoquer un incendie ou une explosion causant des dégâts matériels, des blessures ou la mort.

– Ne pas ranger ou utiliser de la gazoline ou d'autres liquides ou gaz inflammables à proximité de cet appareil ou d'un autre du même type.

#### – **QUE FAIRE SI VOUS DÉTECTEZ UNE ODEUR DE GAZ**

- Ne pas tenter d'allumer l'appareil.
  - Ne toucher à aucun interrupteur électrique ; n'utiliser aucun appareil téléphonique dans l'immeuble.
  - Contacter immédiatement votre fournisseur de gaz à partir du téléphone d'un voisin. Suivre les instructions données par votre fournisseur de gaz.
  - S'il est impossible de rejoindre le fournisseur de gaz, appeler le service des incendies.
- L'installation et l'entretien doivent être effectués par un installateur qualifié, une société d'entretien ou le fournisseur de gaz.

### TO BE COMPLETED BY THE INSTALLER

Service Agency \_\_\_\_\_ Phone No. \_\_\_\_\_

Address \_\_\_\_\_

Boiler Model No. \_\_\_\_\_ Serial No. \_\_\_\_\_ Date of Installation: \_\_\_\_\_



PeerlessBoilers.com

**PB HEAT, LLC**

131 S. CHURCH ST • BALLY, PA 19503

PF8147 R0 (8/11-1.5M)

Printed in U.S.A.

©2011 PB Heat, LLC. All rights reserved.

## Basic Operation

### **WARNING**

Service on this boiler should be undertaken only by trained and skilled personnel from a qualified service agency.

### **CAUTION**

Should overheating occur or the gas supply fail to shut off, do not turn off or disconnect the electrical supply to the pump. Instead, shut off the gas supply at a location external to the appliance.

En cas de surchauffe ou si l'alimentation ne se coupe pas, ne pas éteindre manuellement ni couper l'alimentation électrique de la pompe. Couper plutôt l'alimentation en combustible à l'extérieur de l'appareil

Do not use this boiler if any part has been under water. Immediately call a qualified service agency to inspect the boiler and to replace any part of the control system and any gas control which has been under water.

- A. **General:** This appliance is a sealed combustion, condensing water boiler and is equipped with controls for proper operation. All controls must be maintained in proper working order. Contact a qualified service agency to provide annual maintenance as specified in the Installation, Operation and Maintenance Manual.
- B. The following diagram shows the safety controls and device locations on the appliance. If any one of these controls or devices are activated, contact a qualified service person immediately. **Do not try to correct the problem without contacting a qualified service person.**
1. **Primary Safety Control:** The primary safety control monitors all limit controls and will prevent the appliance from operating if a limit has been exceeded. This device also monitors blower speed and temperature to assure safe operation of the appliance.
  2. **High Vent Temperature Limit:** This device interrupts appliance operation if the vent temperature exceeds the maximum allowable temperature of the vent material. The control display module will display "HIGH STACK TEMPERATURE" if this device is activated.
  3. **High Temperature Limit:** This device automatically interrupts boiler operation if the supply water temperature exceeds 210°degrees Fahrenheit. The primary safety control will not allow the unit to restart until the reset button is depressed on the display module. The control will display "OVERHEAT LIMIT OPEN" if the device is activated.
  4. **Flame Sensor:** The flame sensor monitors the flame and communicates with the primary safety control to interrupt the gas flow to the appliance if no flame is present. The primary safety control will lock out if the flame sensor malfunctions producing a false flame signal. The control will display "IGNITION ERROR," "FLAME FAILURE," or "FALSE FLAME DETECTED" if this device is activated.
  5. **Safety Relief Valve:** This valve protects the boiler from excessive pressure. This device can discharge a large amount of hot water and should be piped to discharge near the floor and away from contact with people. The discharge should be piped near a floor drain if possible.
  6. **Gas Valve:** This valve interrupts the gas flow if no power is present from the primary safety control.
  7. **Condensate Float Switch:** This device automatically interrupts boiler operation if there is a blockage in the condensate drain system. The control display module will display "BLOCKED CONDENSATE DRAIN" if the device is activated.
  8. **Vent Pressure Switch:** This device automatically interprets boiler operation if there is blockage in the exhaust vent. The control display module will display "BLOCKED VENT" if the device is activated.

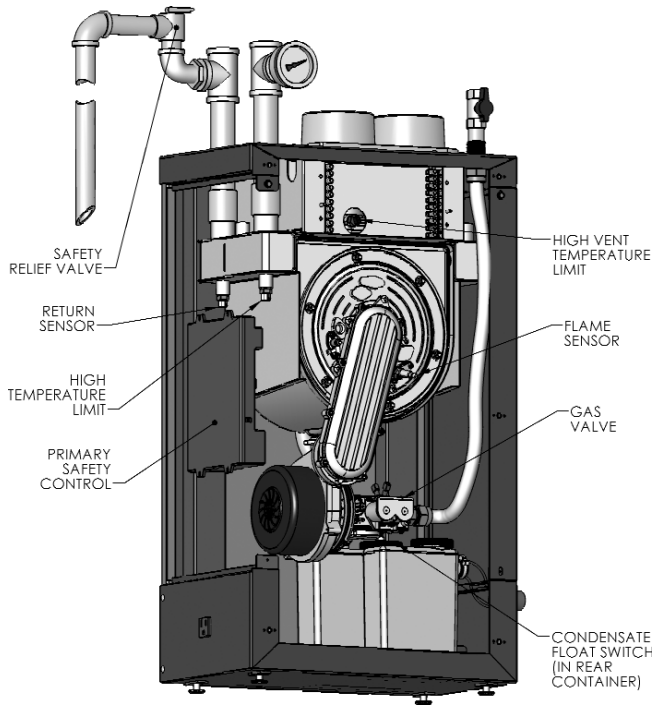

**Figure 1: Control & Safety Device Locations – PF-50 through PF-140 Models**

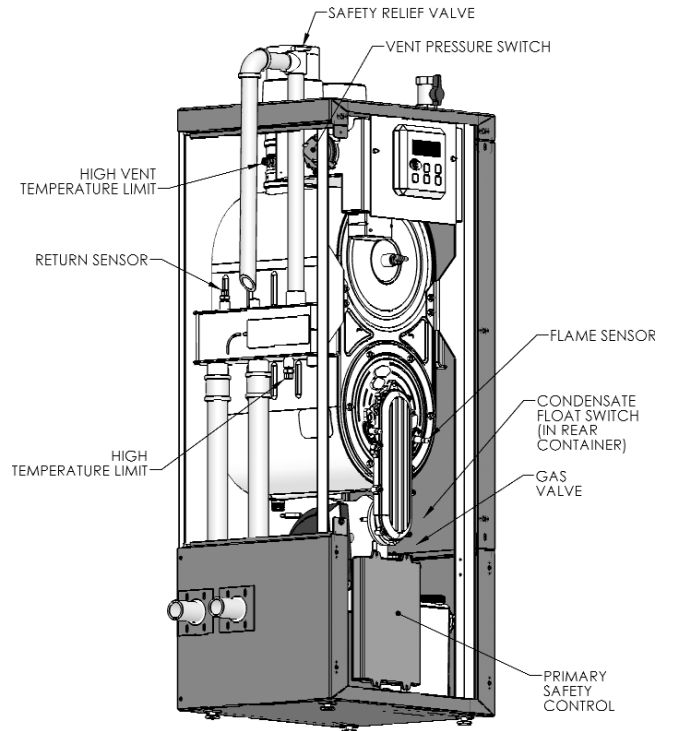

**Figure 2: Control & Safety Device Locations – PF-210/399**

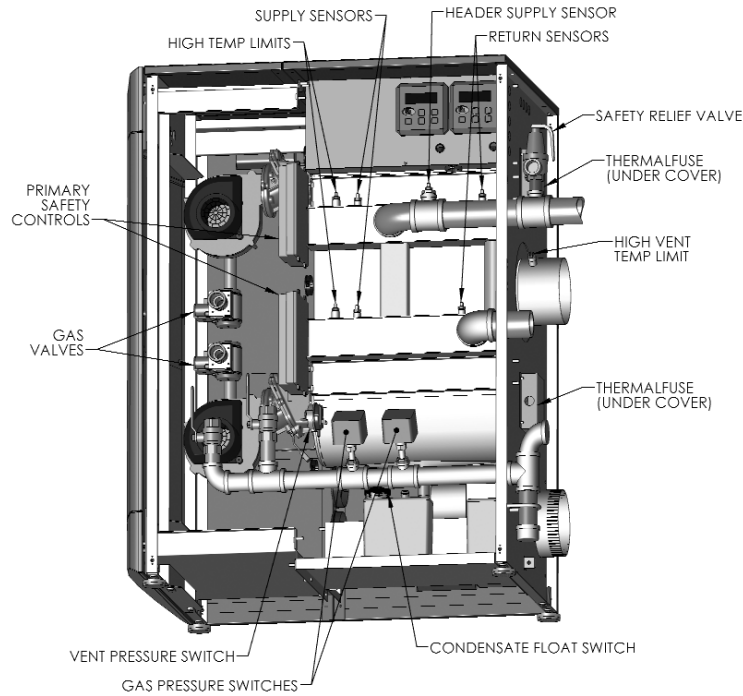

**Figure 3: Control & Safety Device Locations – PF-850/1000**

- C. Instructions for operation and shutting down your boiler are shown on the Operating and Lighting Instructions Label posted on the back of the boiler cover. The instructions are also shown in Figure 4.
- D. The sequence of operation is shown in Figure 5.

## FOR YOUR SAFETY READ BEFORE OPERATING

**WARNING:** If you do not follow these instructions exactly, a fire or explosion may result causing property damage, personal injury, or loss of life.

- A. This appliance does not have a pilot. It is equipped with an ignition device which automatically lights the burner. Do not try to light the burner by hand.
- B. **BEFORE OPERATING** smell all around the appliance area for gas. Be sure to smell next to the floor because some gas is heavier than air and will settle on the floor.

### WHAT TO DO IF YOU DO SMELL GAS

- Do not try to light any appliance.
  - Do not touch any electric switch; do not use any phone in your building.
  - Immediately call your gas supplier from a neighbor's phone. Follow the gas supplier's instructions.
- D. Do not use this appliance if any part has been under water. Immediately call a qualified service technician to inspect the appliance and to replace any part of the control system and any gas control which has been under water.
- C. Use only your hand to turn the gas control valve. Never use tools. If the handle will not turn by hand, don't try to repair it, call a qualified service technician. Force or attempted repair may result in a fire or explosion.

## OPERATING INSTRUCTIONS

1. **STOP!** Read the safety information above.
2. Set the thermostat to lowest setting.
3. Turn off all electric power to the appliance.
4. This appliance is equipped with an ignition device which automatically lights the burner. Do not try to light the burner by hand.
5. Turn gas shutoff valve(s) clockwise  $\cup$  to "OFF". Handle will be perpendicular to pipe, do not force.
6. Wait five (5) minutes to clear out any gas. Then smell for gas, including near the floor. If you smell gas, **STOP!** Follow "B" in the safety information above on this label. If you don't smell gas, go to the next step.
7. Turn gas shutoff valve(s) counterclockwise  $\cup$  to "ON". Handle will be in line with the pipe.
8. Turn on all electric power to appliance.
9. Set thermostat to desired setting.
10. If the appliance will not operate, follow the instructions "To Turn Off Gas To Appliance" and call your service technician or gas supplier.

Single Burner Models

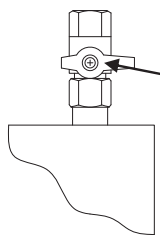

Gas Control Knob(s)  
(shown in the  
"OFF" position)

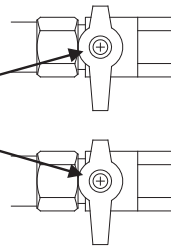

Two Burner Models (Commercial)

## TO TURN OFF GAS TO APPLIANCE

1. Set the thermostat to lowest setting.
2. Turn off all electric power to the appliance if service is to be performed.
3. Turn the gas shutoff valve(s) clockwise  $\cup$  "OFF". Handle will be perpendicular to pipe, do not force.

(PF)

9512 REV 0

Figure 4: Lighting and Operating Instructions

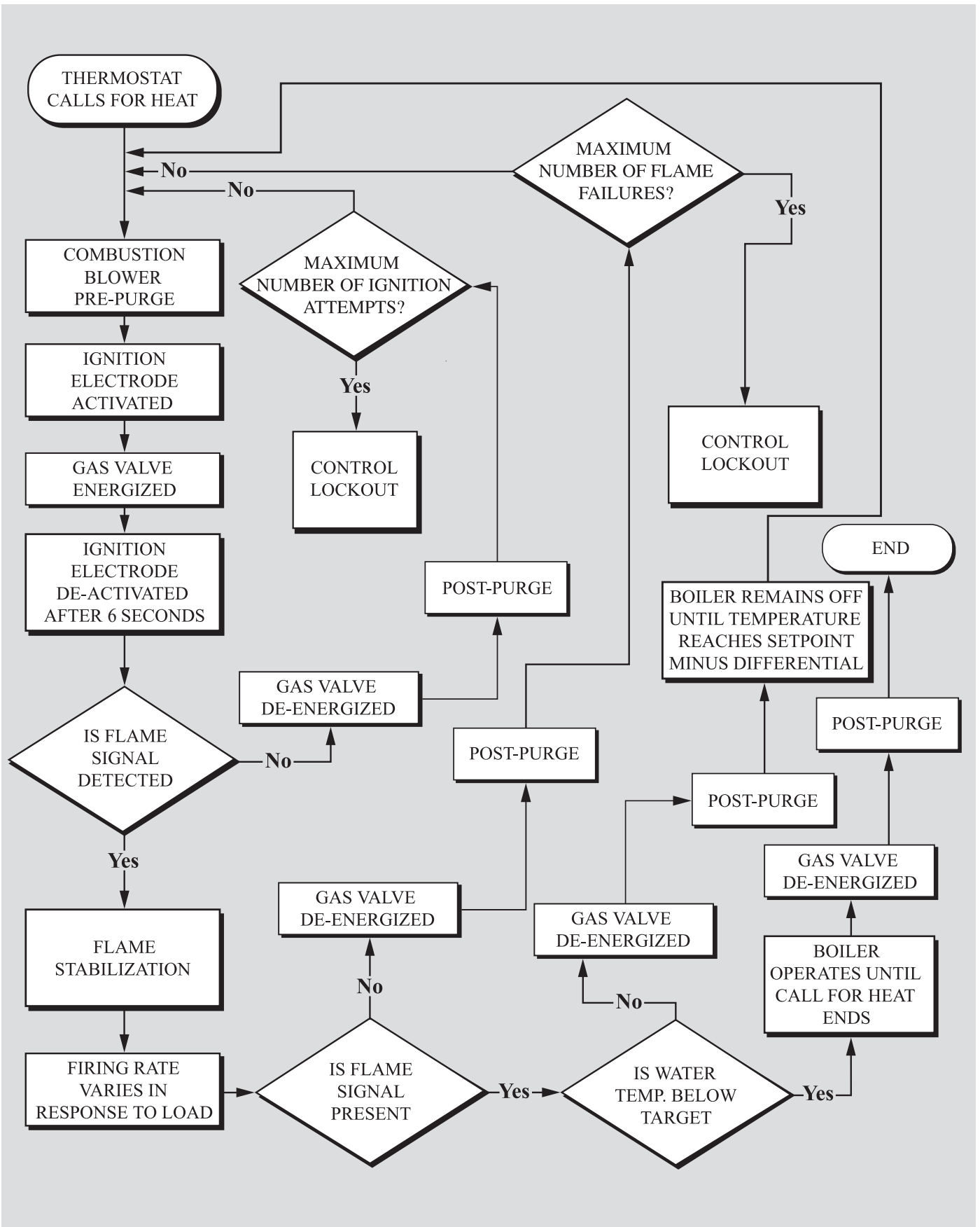

Figure 5: Sequence of Operation

## User Maintenance

### **WARNING**

**Service on this boiler should be undertaken only by trained and skilled personnel from a qualified service agency. Inspections should be performed at intervals specified in the Installation, Operation and Maintenance Manual and this User's Information Manual. Maintain manuals in a legible condition.**

**Keep boiler area clear and free of combustible materials, gasoline and other flammable vapors and liquids.**

**Do not place any obstructions in boiler room that will hinder flow of combustion and ventilation air.**

#### **A. General Housekeeping (Continuous)**

1. Keep the area around this appliance clear and free of combustible materials and obstructions.
2. Do not store or use flammable vapors or liquids, such as gasoline, in the vicinity of the boiler. This applies to any fossil fuel-fired appliance.
3. Do not store or use any sources of hydrocarbons in the vicinity of this appliance.
4. Do not store or use any sources of hydrocarbons in the vicinity of the inlet air termination. If the source of hydrocarbon contamination cannot be removed, the combustion air must be re-piped to a different location.
5. Sources of hydrocarbons include bleaches, detergents, cleaning solvents, chlorinated waxes or cleaners, chlorine based swimming pool chemicals, rock salt or other chloride based ice melt solutions, water softener salt, refrigerants, paint or varnish removers, fabric softeners, hydrochloric acid or muratic acid, cements, glues and adhesives.

#### **B. Inspect Venting / Air Inlet System (Monthly)**

1. Inspect the vent pipe and assure that it is continuous with no separations, obstructions, sags, discoloration, depressions or deformation. Vent pipe must be supported at minimum 4 foot (122 cm) intervals and secured with adhesive specifically formulated for the material used.

### **WARNING**

**Failure to inspect the venting system and, if problems are found, to notify a qualified service technician, may result in boiler exhaust entering the structure and causing severe personal injury or death from carbon monoxide poisoning and oxygen depletion.**

2. Air inlet piping must be continuous from the air inlet termination to the boiler with no separations, obstructions or sags. Air inlet piping must be supported at minimum 4 foot (122 cm) intervals and secured with adhesive specifically formulated for the material used.
3. Inspect around the vent and air inlet terminations outside the home for obstructions. Keep area clear of snow and debris. Inspect also for any gaps at the wall penetration(s) which could allow vented gasses to reenter the home.
4. Notify a qualified service contractor if any problems are found with the venting or air intake systems and be sure that the problems are corrected.

### **C. Inspect Pressure Relief Valve (Monthly)**

1. Inspect the pressure relief valve outlet for signs of leakage.
2. Notify a qualified service contractor immediately if there are signs of leakage. (If the problem persists, it may be the result of a malfunctioning expansion tank or improper system design).

### **D. Inspect Condensate Drain System (Monthly)**

1. With the boiler in operation with a call from the thermostat, check that condensate is flowing in the condensate tubing. Check for any blockage or restriction in the condensate drain lines.

## **WARNING**

**Do not operate the boiler with the condensate drain line disconnected. If there is evidence of exhaust leakage from the condensate drain line, turn off the unit and contact a qualified service contractor. These conditions may result in boiler exhaust entering the structure and causing severe personal injury or death from carbon monoxide poisoning and oxygen depletion.**

2. Check the condensate drain piping for visible water leaks.
3. Check the level of condensate neutralization media (where used) in the front condensate collector.
4. PF-50 through PF-399 – Check the vent hole on the top tee outlet of the condensate drain pipe. Make sure there are no exhaust emissions leaking from this hole.
5. Notify a qualified service contractor immediately if there are signs of leakage, blockage, or depleted neutralization media.

### **E. Observe Boiler Operation (Monthly)**

1. Initiate a call for heat from the system by turning up a room thermostat or draining hot water at a faucet (if an indirect water heater is used).
2. Observe the boiler start and listen for objectionable noises during the start-up.
3. Contact a qualified service person if objectionable sounds are observed.

### **F. Control Inspection and Maintenance (As Required by Control Manufacturer)**

1. Safety Relief Valve. Conduct try lever test as outlined in manufacturer's instruction tag on the safety relief valve.
2. Low Water Cut-off (if used). Follow instructions provided by control manufacturer.

### **G. General Inspection and Maintenance (Annual)**

Annual inspection and service is to be performed by a qualified service contractor as specified in the Installation, Operation and Maintenance Manual supplied to the installer with the boiler. If a copy of the original Installation, Operation and Maintenance Manual is not available a new copy is available at [PeerlessBoilers.com](http://PeerlessBoilers.com) or from your local PB Heat Representative.

## H. Error Handling

B L O C K I N G   E R R O R      1 6 : 3 6  
F a n   P o s t   P u r g e

B L O C K I N G   E R R O R      1 6 : 3 6  
#

**Blocking Error:** "Blocking Error" is displayed whenever a condition is reached that prevents the boiler from operating but will not result in a control lockout. Once the condition is corrected, the control will reset automatically. See Installation, Operation & Maintenance Manual for a list of blocking errors.

L O C K O U T   E R R O R      1 6 : 3 6  
F a n   P o s t   P u r g e

L O C K O U T   E R R O R      1 6 : 3 6  
#

**Lockout Error:** "Lockout Error" is displayed whenever a condition is reached that results in a control lockout. After the condition is corrected, the control requires the reset button to be pushed in order to resume operation. See Installation, Operation & Maintenance Manual for a list of lockout errors.

S E R V I C E                      1 6 : 3 6  
S T A N D B Y

1 6 0 ° F

**Service Indicator:** Predetermined service intervals can be programmed into the control to prompt end users to call for routine service. This interval can be set to "TIME", "HRS" or "CYCLES" in the Installer Menu.